

CONFIDENTIALITY
 THE CONTENTS OF THIS DRAWING INCLUDE CONFIDENTIAL INFORMATION WHICH IS THE SOLE PROPERTY OF D-PACE. ANY USE, DISCLOSURE OR REPRODUCTION OF THIS DRAWING, IN WHOLE OR IN PART, WITHOUT THE PRIOR WRITTEN AUTHORIZATION OF D-PACE IS STRICTLY PROHIBITED.

REVISION HISTORY						
REV	DESCRIPTION	DCN	BY	DATE	APPROVED	
A	INITIAL RELEASE - DERIVED FROM DWG 1800636			5/27/2016	D.POTKINS	

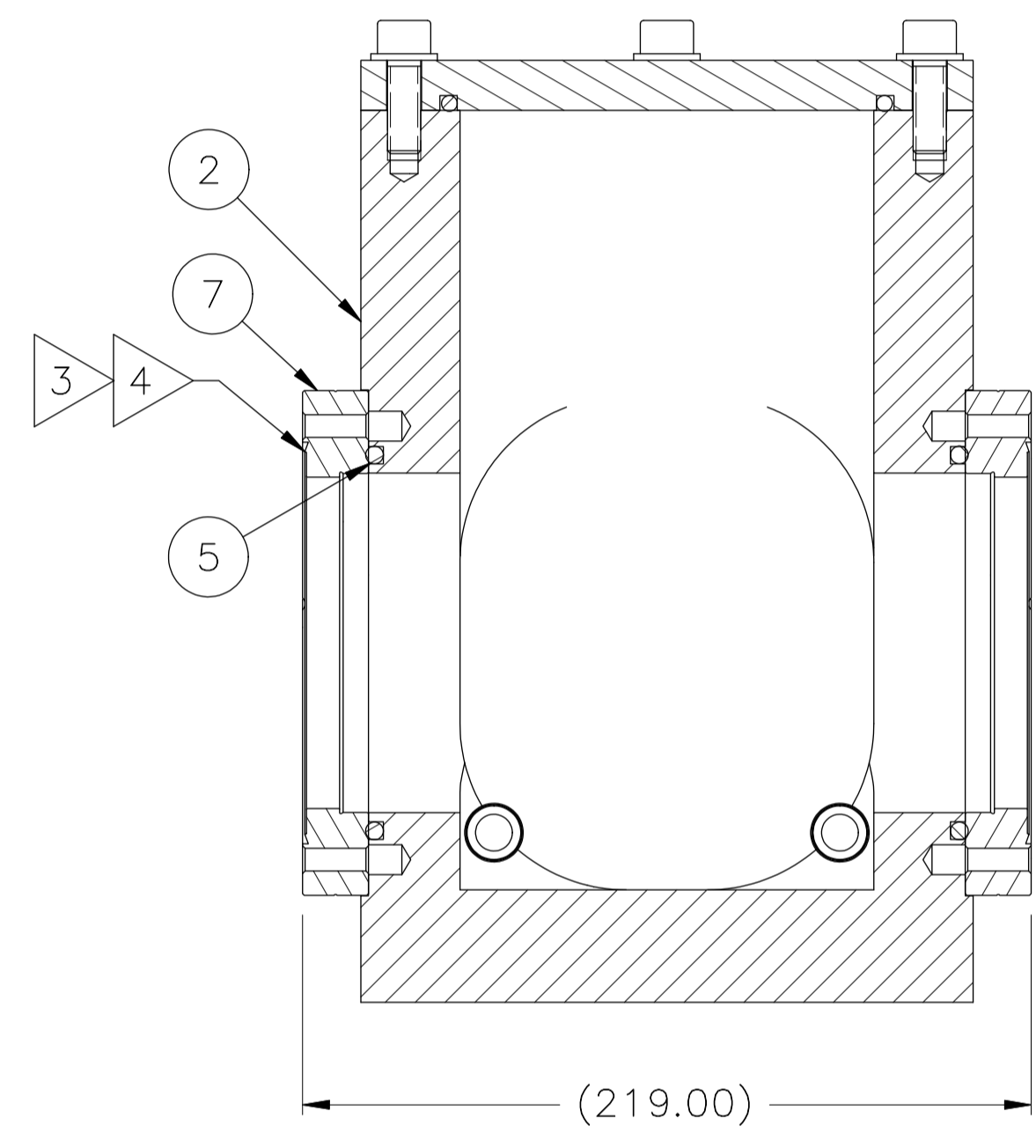

SECTION A-A

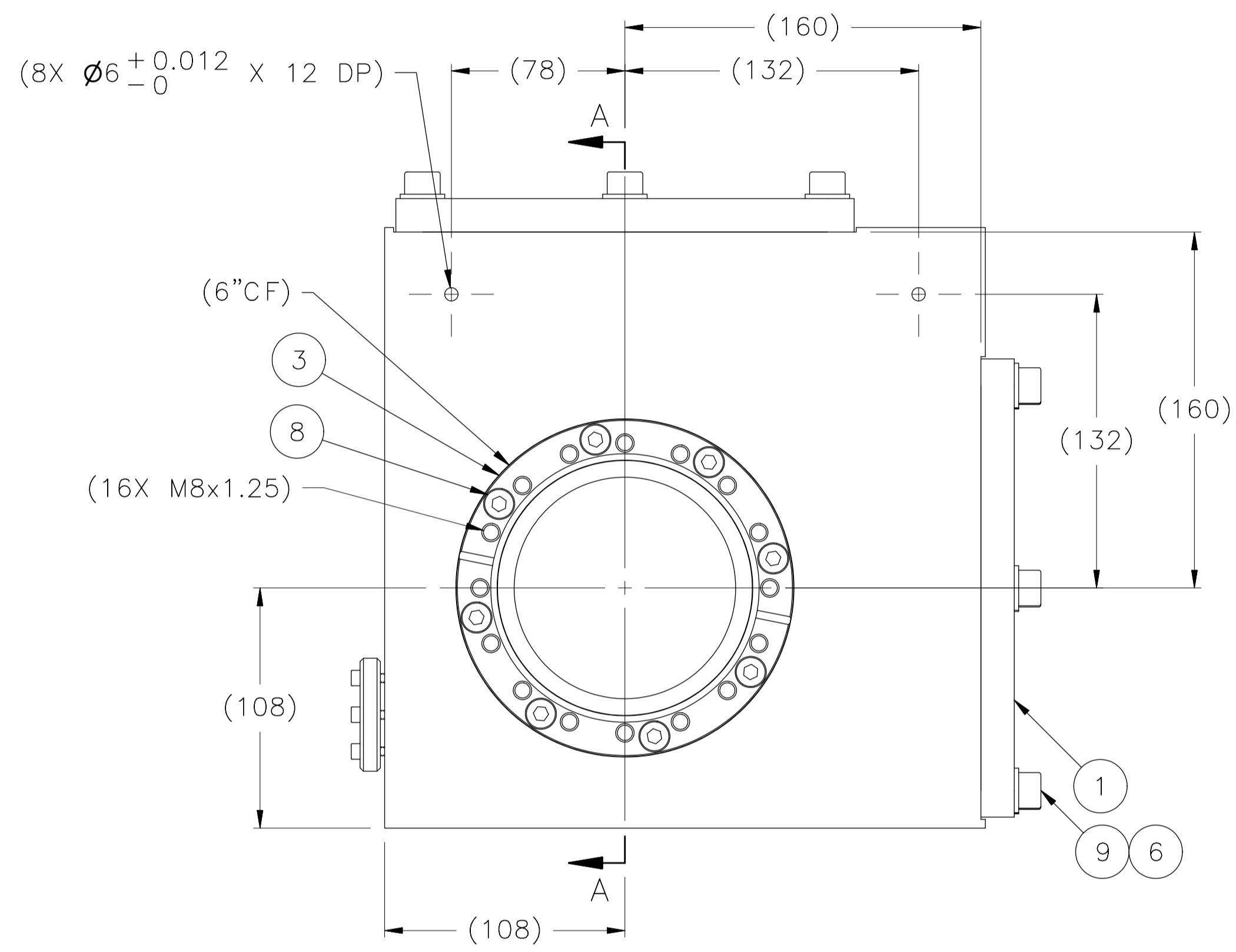
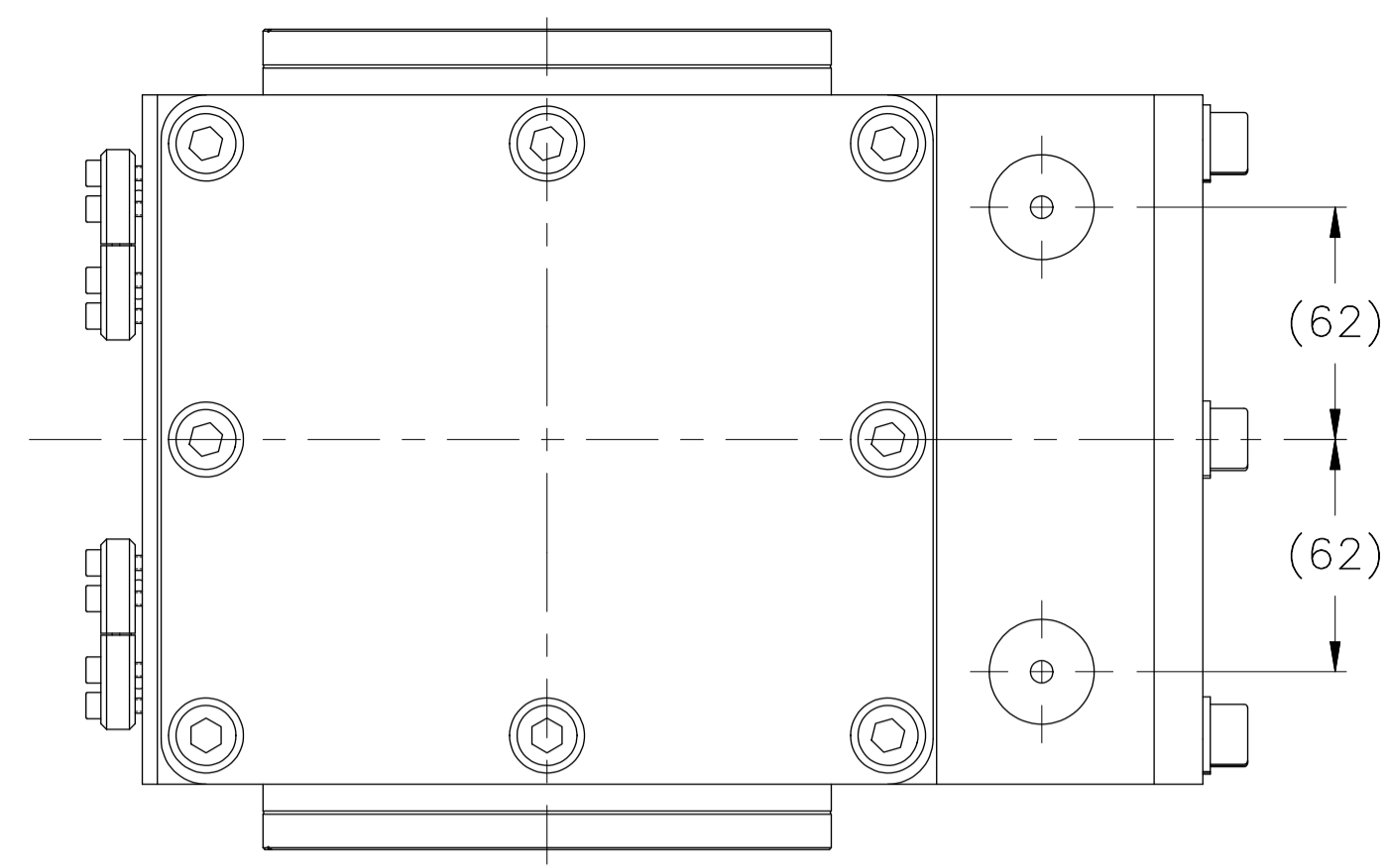
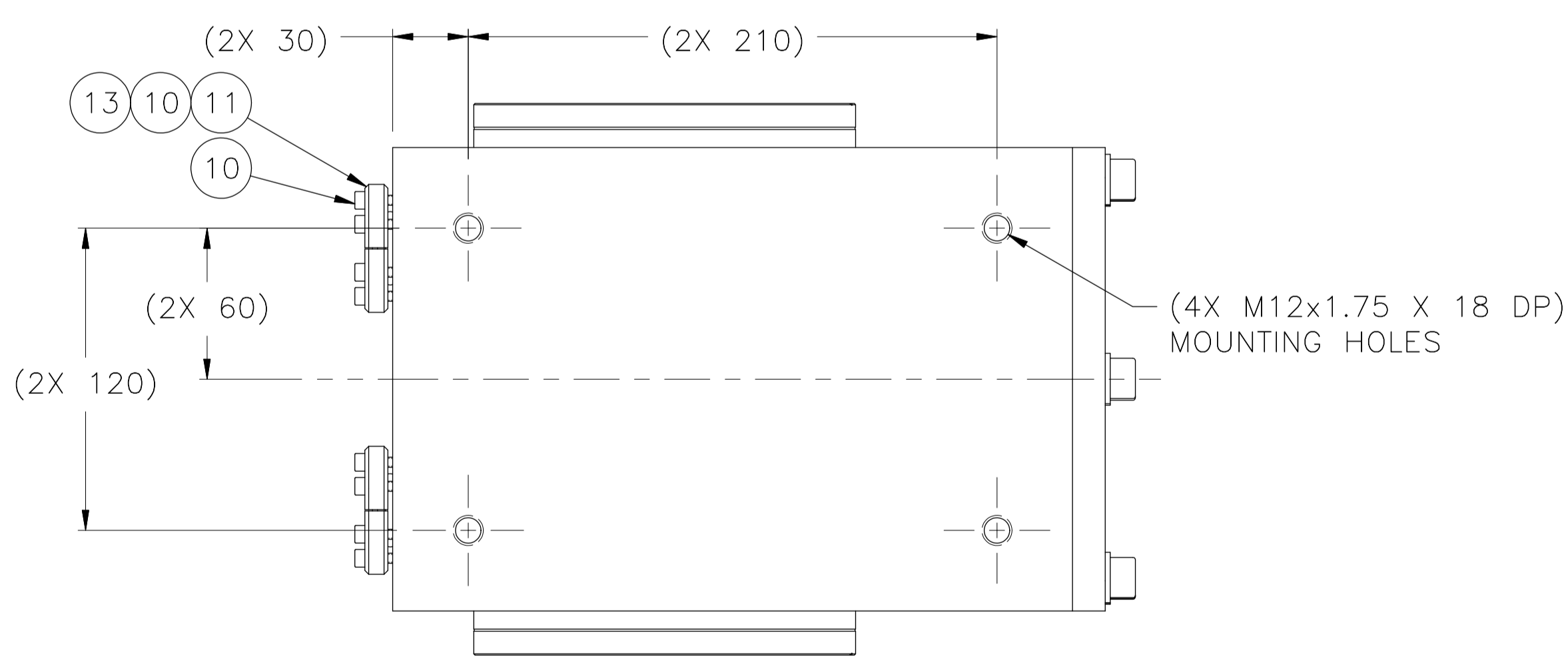
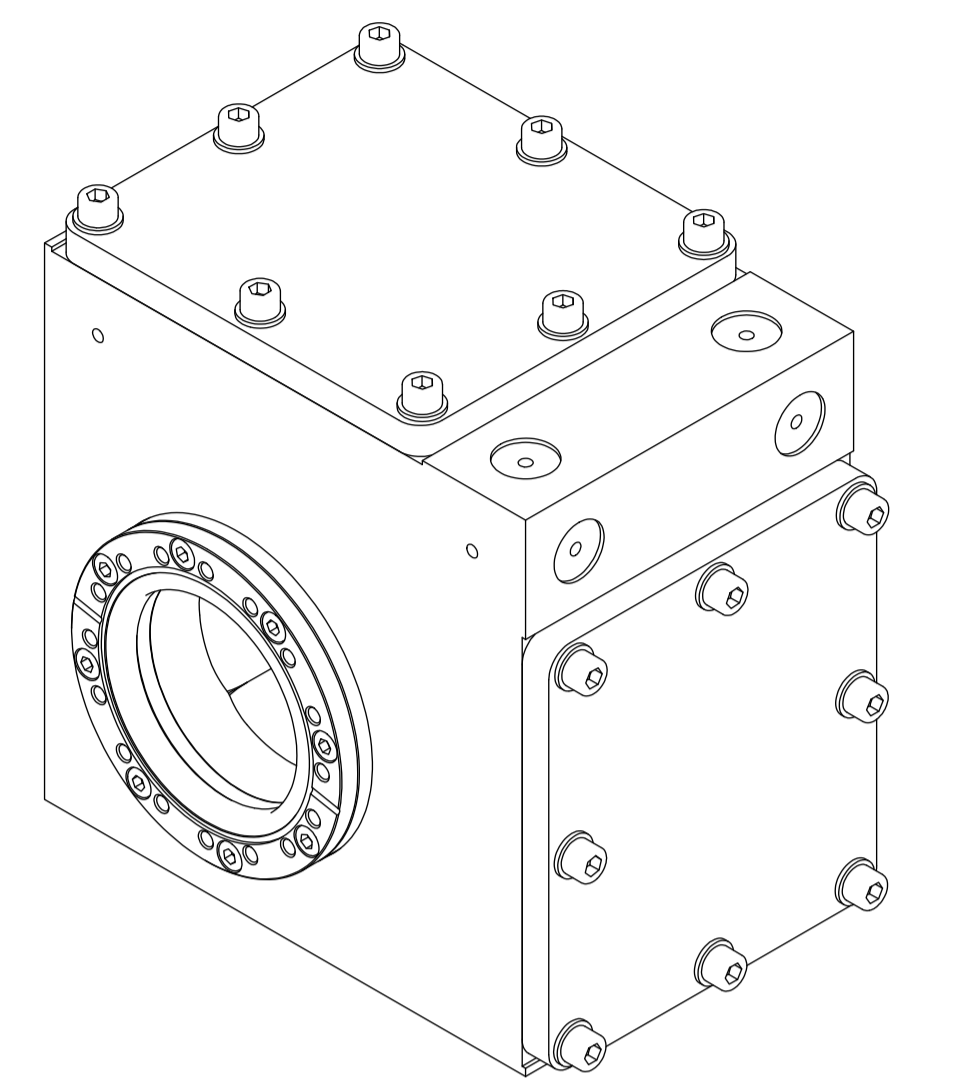
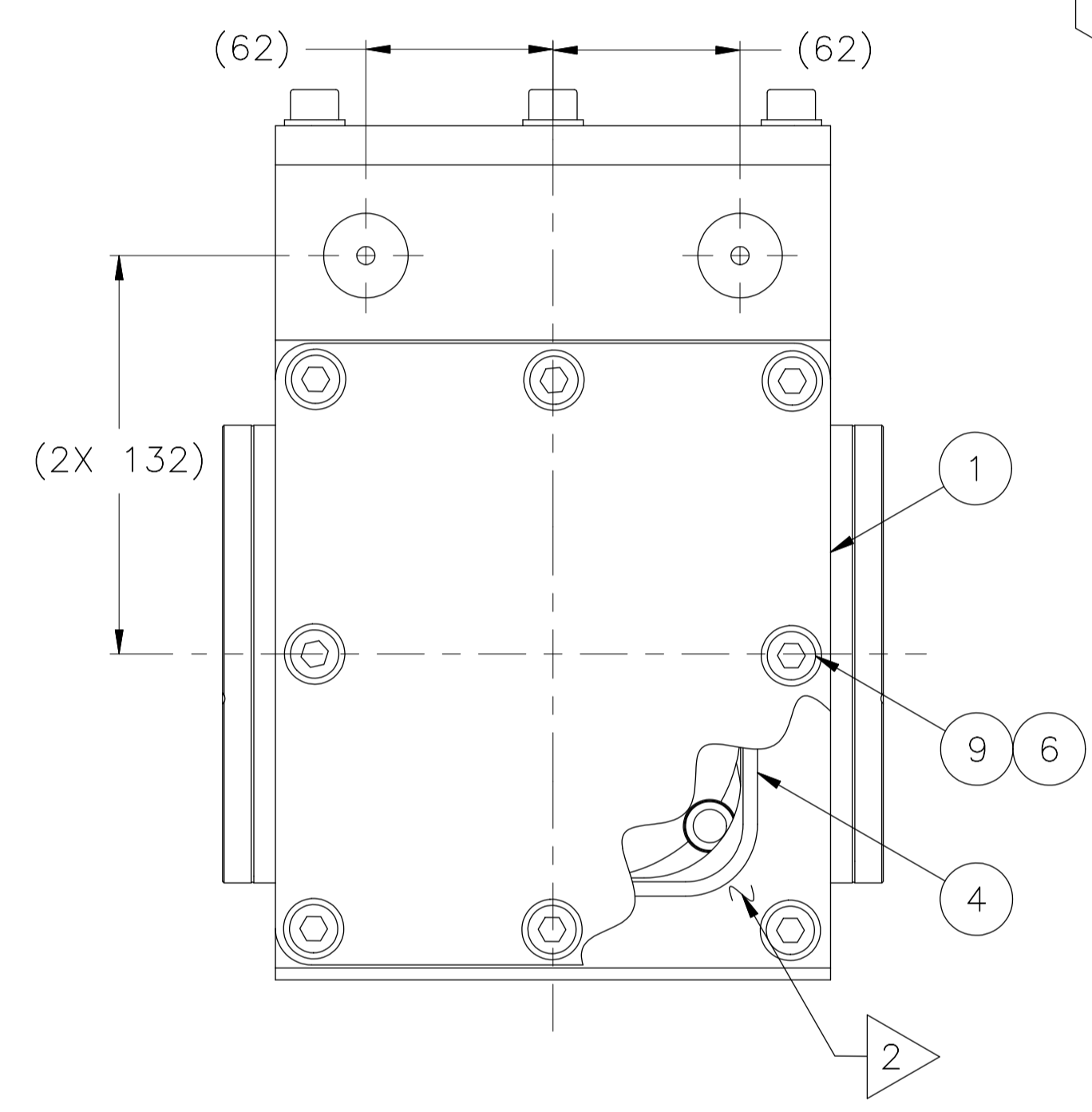

NOTES:

- CLEAN, HANDLE, PACKAGE & STORE COMPONENT IN ACCORDANCE WITH D-PACE SPECIFICATION 2020003.
- PROTECT FLANGE SEALING SURFACE FROM DAMAGE. NO NICKS, SCRATCHES OR DENTS ON KNIFE EDGE.
- LEAK CHECK ALL WELD JOINTS & SEAL JOINTS, ANY LEAKS IN EXCESS OF 5×10^{-9} ATM CC/SEC. MUST BE REPAIRED AND RE-TESTED.
- COVER OPEN PORTS ON VACUUM BOX WITH ITEM 7 TO PROTECT ASSEMBLY FROM CONTAMINATION DURING TRANSIT.

ITEM	QTY	PART NUMBER	DESCRIPTION
13	2	QF16-075-ARB	CENTERING RING, KF (QF) 16, AL, BUNA-N, KJL
12	2	QF16-075-AB	BLANK FLANGE KF (QF) 16, AL, KJL
11	2	QF16-075-BC	BULK HEAD CLAMP KF (QF) 16, AL, KJL
10	12		SCREW, SHC, M4 X 20 LG, SS
9	16		SCREW, SHC, M10 X 30 LG, SS
8	16		SCREW, SHC, M8 X 25 LG, SS
7	A/R		GLASS PROTECTION TAPE, ULINE
6	16		WASHER, FLAT, M10, SS
5	2		O-RING, #-347, VITON
4	2		O-RING, #-362, VITON
3	2	1901683	FLANGE, DIRECT MOUNT 6 CF" W/ M8 & O-RING
2	1	1901674	V-BOX, DUAL ES-4, CF 6" & O-RING
1	2	1901439	FLANGE, BLANK, ES-4

DO NOT SCALE FROM DRAWING		APPROVALS		DATE	 DEHNEL - PARTICLE ACCELERATOR COMPONENTS & ENGINEERING, INC. P.O. BOX 201, NELSON BC, CANADA, V1L 5P9 TEL: (250) 352-5162 www.d-pace.com
METRIC DRAWING		DRAWN	DATE		
ALL DIMENSIONS IN MILLIMETRES		J.THEROUX	5/20/2016		
TOLERANCES UNLESS OTHERWISE SPECIFIED		CHECKED	5/27/2016		
LINEAR	X ±1	T.STEWART	5/27/2016		TITLE V-BOX, DUAL ES-4, CF 6" W/ M8, O-RING
	X.X ±0.3	DESIGNED	2016		
	X.XX ±0.1	MODELED	5/20/2016		
	X.XXX ±0.03	J.THEROUX	5/20/2016		
ANGULAR	±0.5°				SIZE
SURFACE FINISH 1.6√				ES-4	DRAWING NO.
THIRD ANGLE PROJECTION				ES-4	1800645
				REV	A
				SCALE 1:2	WEIGHT 22.97 kg SHEET 1 OF 1